

Installation Instructions

Toyota Tacoma 2016-up

Kit Contents

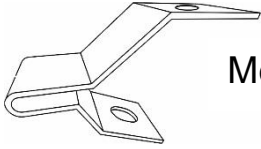

Metal mounting brackets (4)

Pins (4)



Square expansion plug (4)

Anti-abrasion pads (4)



#8 x 7/16+truss head screws (4)

Bumpons (3)

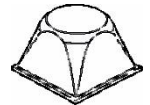

Adhesive pedestals (4)

#6 x 5/8+flat head screws (4)



Push-type retainer (4)

Surface cleaner (1)

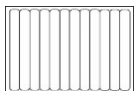

Re-usable tape strips (1)

Hood protector (1)



Installation Procedure

NOTE: Vehicle surface temperature should be a minimum of 15 degree Celsius.

1. Be sure that the hood is clean and dry inside and out.
2. Install the three (3) bumpons as shown

⚠ Attention: Bumpons must be installed on the hood, not on the deflector!!!

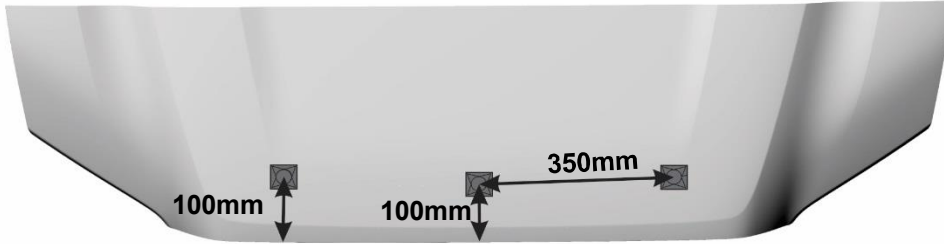

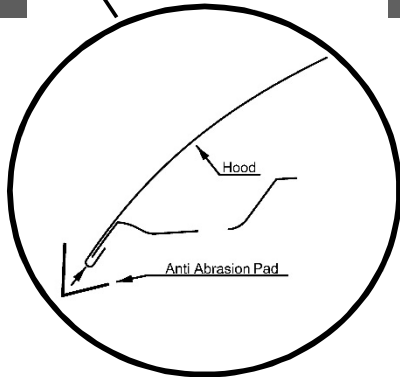
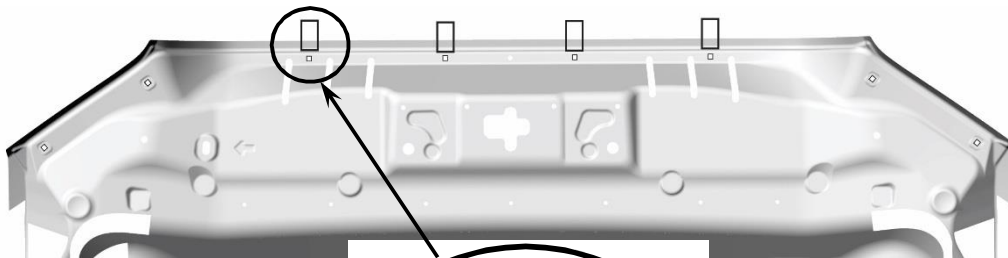

3. Open the hood of the vehicle. Peel and fold the anti-abrasion pads in half over the edge of the hood, in line with the 4(four) holes under the hood, as shown.



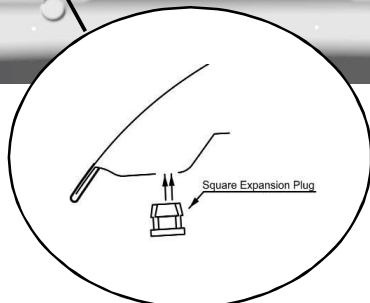
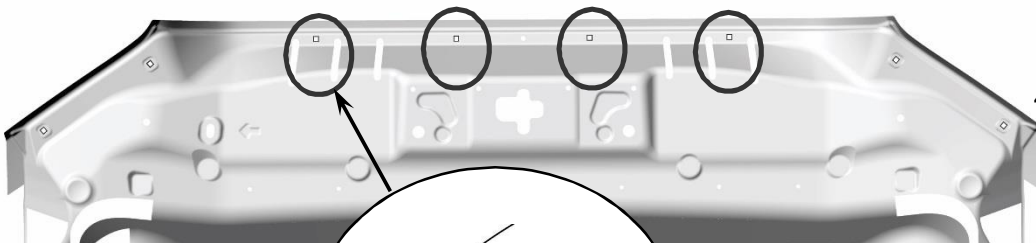

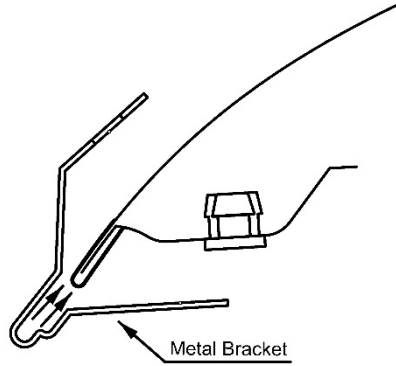
4. Insert square expansion plugs into the holes identified in the illustration.



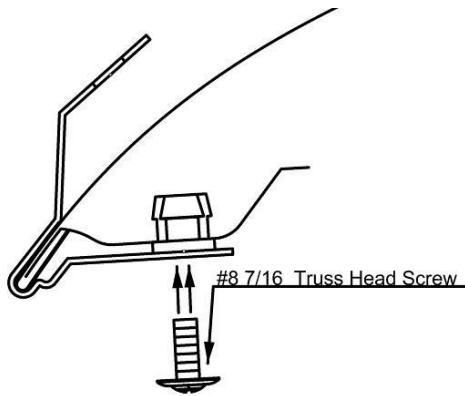

5. Install the four metal brackets on the hood edge over the anti-abrasion pads. Align the hole in the bottom leg of the bracket with the hole in the expansion plug. 



6. Insert a #8 x 7/16+truss head screw through a metal bracket and into an expansion plug in all four locations.  Tighten the screw.

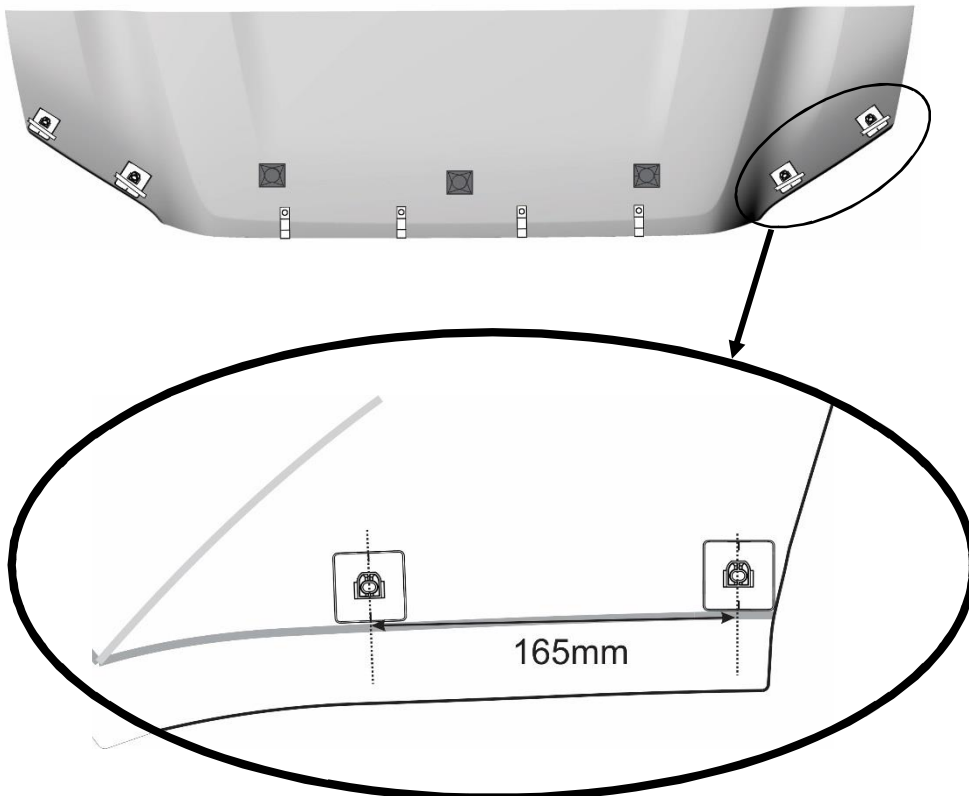

7. Test fit the adhesive pedestals using the supplied tape strips or masking tape to temporarily hold them in position.

***The locations of the pedestals are as illustrated. Measurements are made from the edge of the hood **at** the break from horizontal to vertical. *The outermost pedestal is mounted so the corner of the pedestal is at the edge of the hood as shown.* Pedestals are mounted at the edge but not overhanging the edge.

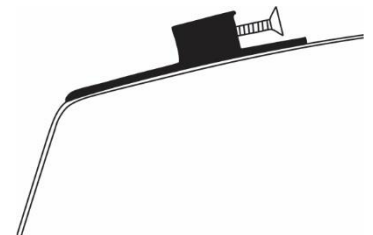

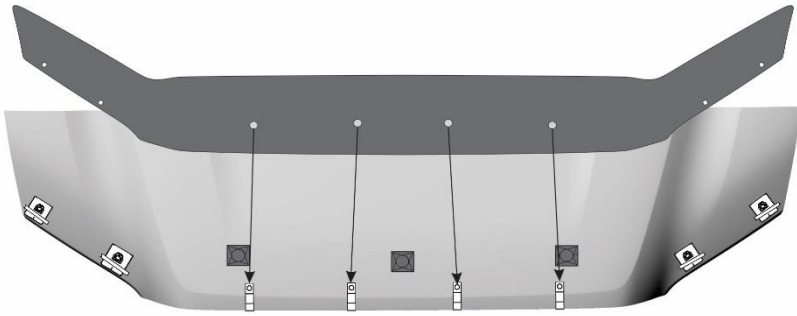

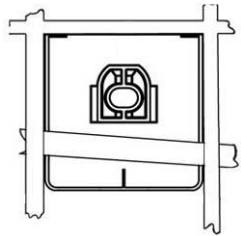

8. Place the protector temporarily onto the metal brackets, aligning the holes in the protector with the holes in the metal brackets. This step will allow you to check the position of the adhesive pedestals and adjust if necessary.

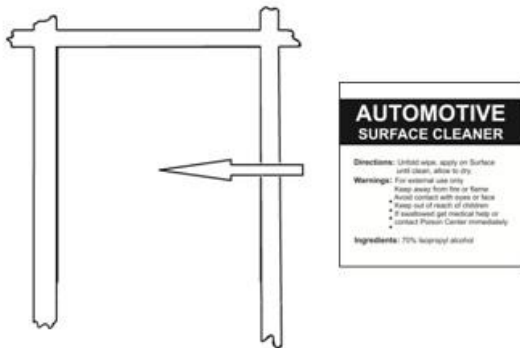

9. Remove the hood protector. Outline the perimeter of the adhesive pedestals with the tape strips or masking tape.



10.  Remove the pedestals and thoroughly clean the outlined area with the automotive surface cleaner, followed by drying with a paper towel or clean cloth. This will ensure maximum adhesive bond by removing all surface contaminants.

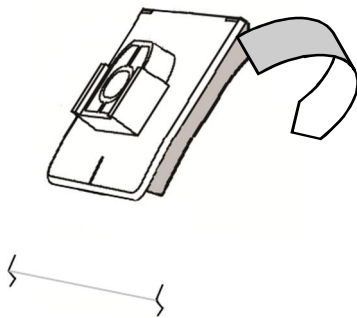

11. Remove the red protective backing from the pedestals using caution to avoid contaminating adhesive surface.
 - Use tape outlines to correctly position the adhesive pedestals on the hood.
 - Remove the tape and ~~wet~~ wet out the adhesive to the hood surface by applying pressure with your thumb around the surface of the pedestals. This will ensure maximum adhesive bond.

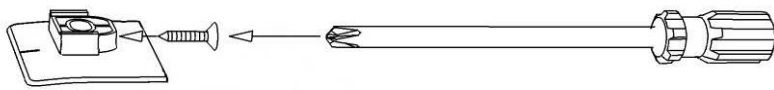

12. Start a screw into each pedestal a few turns. See *illustration*.



NOTE: The tip of the screw must not protrude into the hole where the attachment pin will install later.

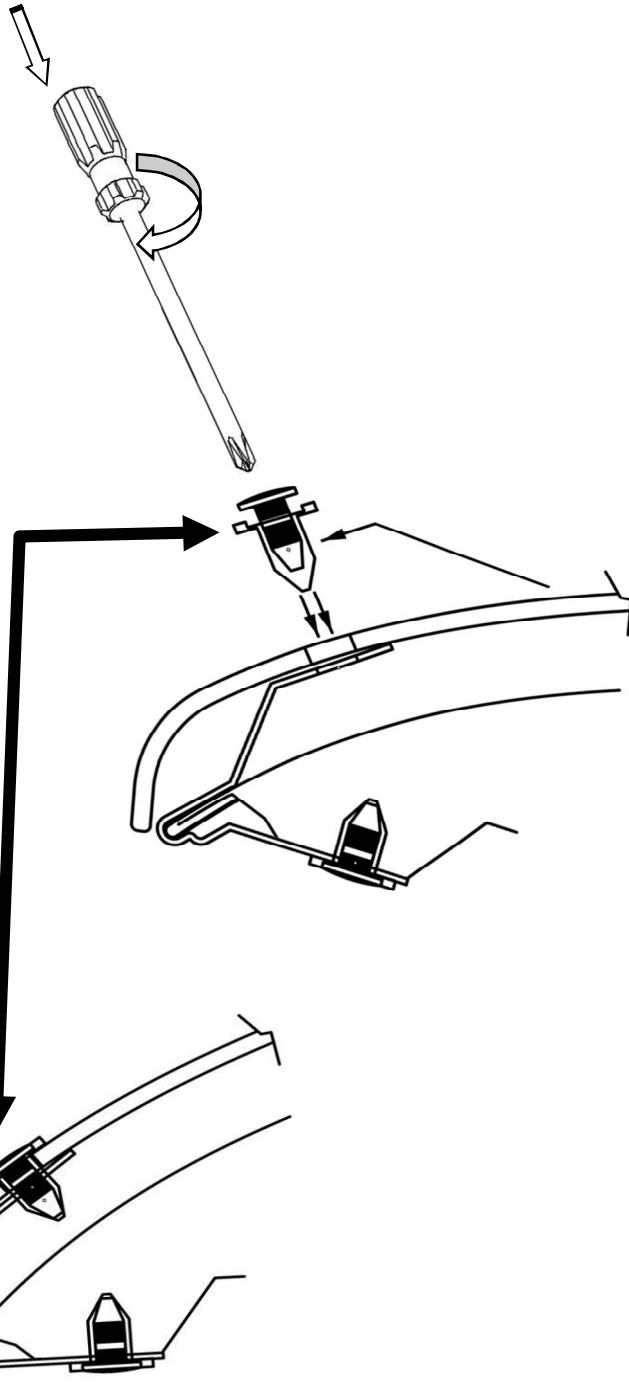

13. Place the protector on the hardware mounted to the hood and align the four (4) holes in the protector with the holes in the metal brackets.



- Insert a push-type retainer through the hole in the protector, and into the bracket.
- Ensure the protector is seated against the metal bracket, push the center pin of the retainer followed by tightening 90 degrees to fully engage the retainer into the metal bracket. Repeat for the remaining metal bracket locations.



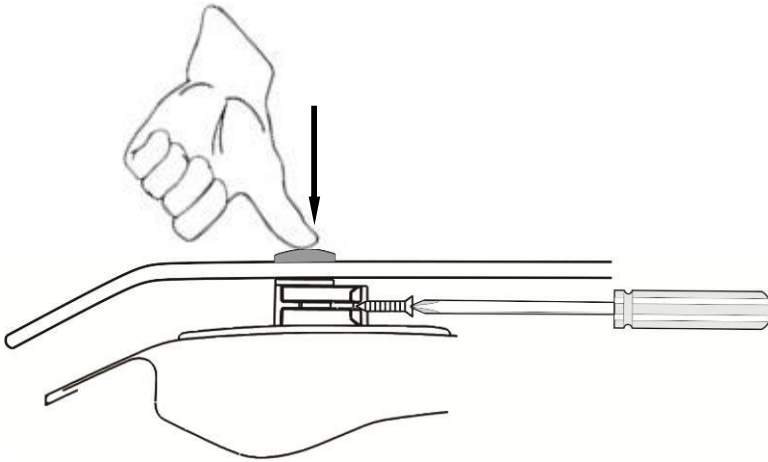
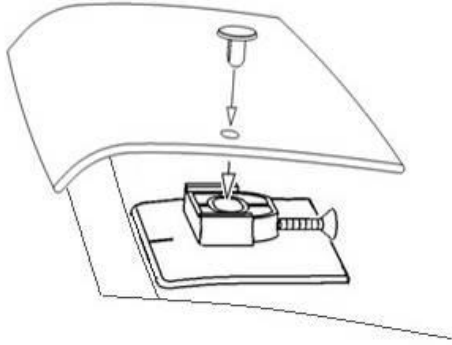

14. Insert a pin through the protector and into each of the four (4) pedestals. Maintain pressure on the head of the pin to ensure the protector is seated against the pedestal and tighten the screw until snug. Do not over-tighten!



CAUTION: Use caution not to damage the hood surface while tightening the screws.



NOTE: Proper installation of the adhesive pedestal system requires the use of a #2 Phillips screwdriver, (long shaft). **See illustration.**

15. On some vehicles it may be necessary to adjust the hood bumpers and/or latch for proper clearance.

Note: *Do not pull on the protector when opening or closing the hood.*

CARE INSTRUCTIONS

Clean the protector with a mild soap and water solution or plastic cleaner only. Do not use chemicals or solvents. Periodically check to make sure the Bumpons are in place and the protector is secure. Do not pull on the protector when opening or closing the hood.